

# KATO NK-1600-V

■寸法図

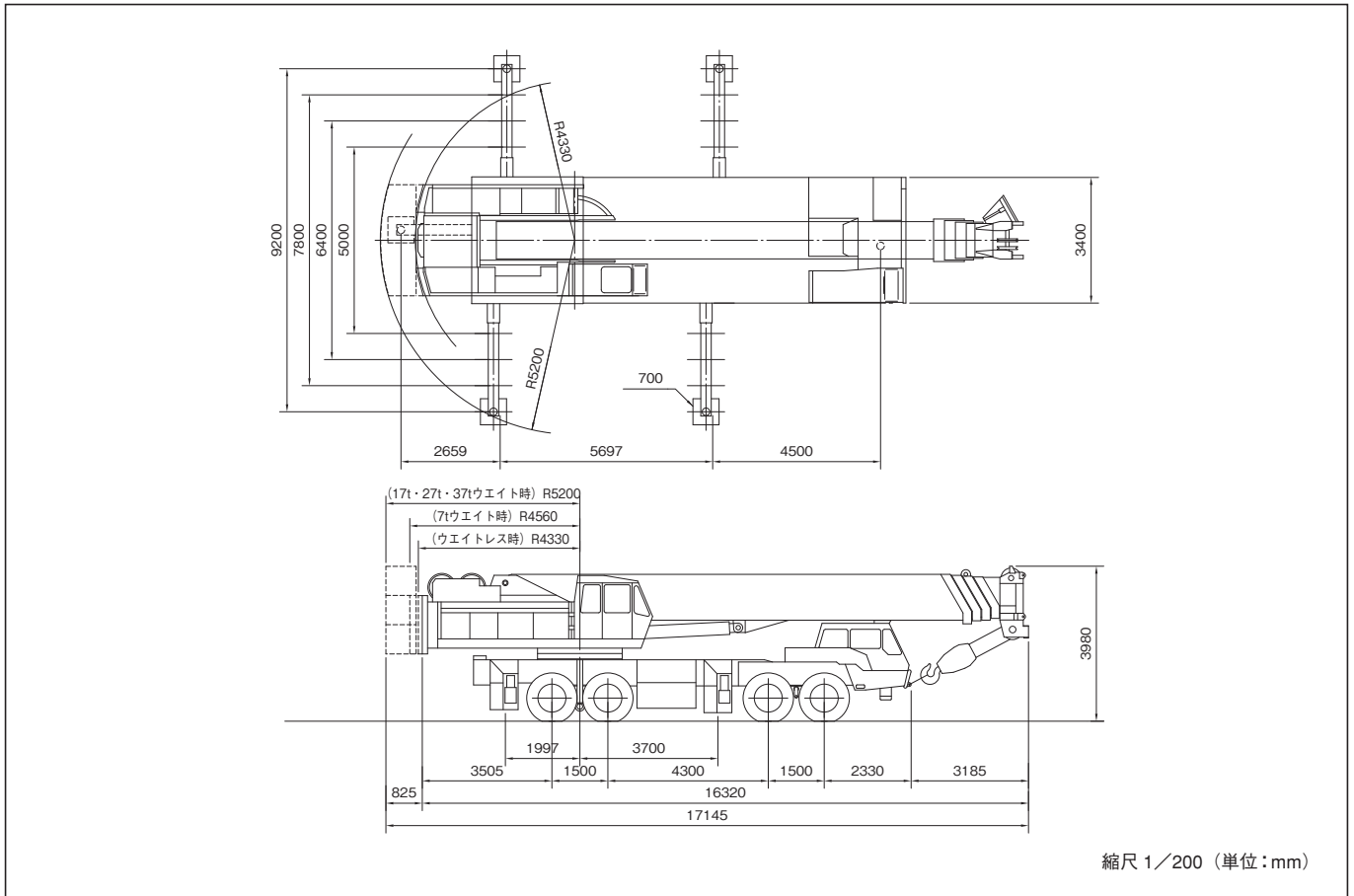

■最少直角通路幅

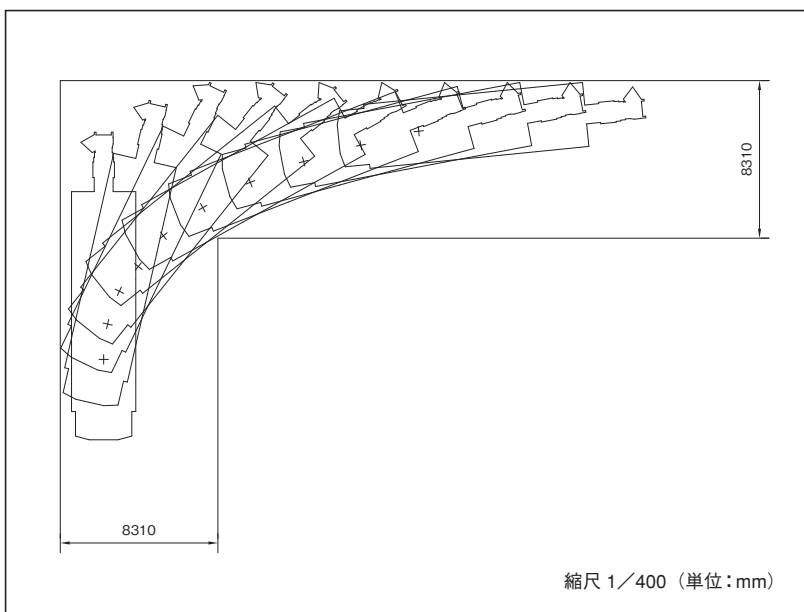

■反力表

条 件	反 力 値
<ul style="list-style-type: none"> <li>・最短ブーム</li> <li>・最小作業半径</li> <li>・無負荷</li> </ul>	42.90t 420.71 kN
<ul style="list-style-type: none"> <li>・最短ブーム</li> <li>・最小作業半径</li> <li>・最大荷重</li> </ul>	88.00t 862.99 kN
<ul style="list-style-type: none"> <li>・最長ブーム</li> <li>・最大作業半径</li> <li>・定格荷重</li> </ul>	91.00t 892.41 kN

NK-1600-V

# KATO NK-1600-V

■作業範囲図

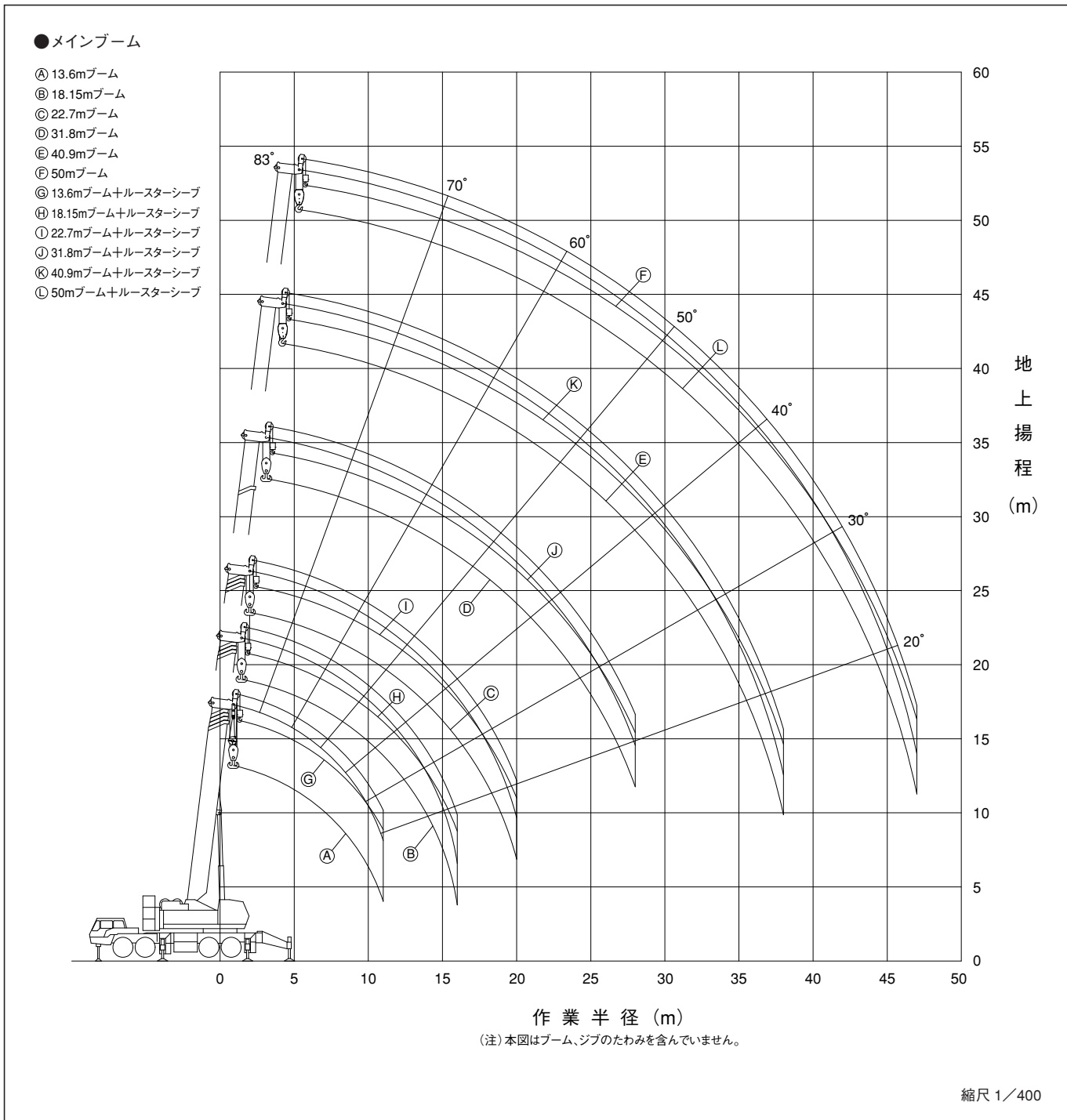

NK-1600-V

作業時全装備重量 (t)	約127 (50mブーム)
--------------	---------------

# KATO NK-1600-V

■定格総荷重表

●13.6~50.0mブーム

(単位:t)

作業半径 (m)	13.6mブーム 性能区分					18.15mブーム 性能区分					22.7mブーム 性能区分				
	A	B	C	D	E	A	B	C	D	E	A	B	C	D	E
3.2	160.0	160.0	160.0	160.0	160.0										
3.5	149.0	149.0	149.0	149.0	149.0	110.0	110.0	110.0	110.0	110.0					
4.0	136.0	136.0	136.0	136.0	136.0	110.0	110.0	110.0	110.0	110.0	100.0	100.0	100.0	100.0	100.0
4.5	123.5	123.5	123.5	123.5	123.5	110.0	110.0	110.0	110.0	110.0	100.0	100.0	100.0	100.0	100.0
5.0	115.5	115.5	115.5	115.5	115.5	107.1	107.1	107.1	107.1	107.1	100.0	100.0	100.0	100.0	100.0
6.0	98.8	98.8	98.8	97.9	92.2	96.9	96.9	96.9	96.2	90.4	84.0	84.0	84.0	84.0	84.0
7.0	85.1	85.1	85.1	80.7	75.9	86.0	86.0	86.0	79.0	74.2	73.4	73.4	73.4	73.4	72.9
8.0	74.8	74.8	74.8	67.9	64.0	76.4	76.4	73.5	66.1	62.2	65.1	65.1	65.1	65.0	61.0
9.0	67.1	67.1	64.4	54.5	53.5	67.3	67.3	62.7	52.8	51.5	58.3	58.3	58.3	51.7	50.3
10.0	62.0	62.0	53.5	45.1	43.0	60.1	60.1	51.8	43.4	41.0	52.6	52.6	50.8	42.4	39.9
11.0	49.0	49.0	45.5	38.2	35.5	54.1	53.3	43.8	36.4	33.6	47.8	47.8	42.8	35.4	32.4
12.0						49.4	47.3	37.6	31.1	28.0	43.7	43.7	36.6	30.1	26.9
14.0						41.4	36.8	28.6	23.3	20.2	37.1	35.8	27.7	22.3	19.1
16.0						23.1	23.1	22.6	18.1	14.9	31.9	27.9	21.5	17.1	13.7
18.0											27.8	22.3	17.1	13.1	10.0
20.0											19.5	18.1	13.8	10.0	7.0
危険角度	—					5°					10°				
標準フック	160tフック					120tフック					120tフック				
フック重量	1,560kg					1,300kg					1,300kg				
巻掛本数	20					13					12				

作業半径 (m)	31.8mブーム 性能区分					40.9mブーム 性能区分					50mブーム 性能区分							
	A	B	C	D	E	A	B	C	D	E	A	B	C	D	E			
5.0	65.0	65.0	65.0	65.0	65.0													
6.0	65.0	65.0	65.0	65.0	65.0													
7.0	61.7	61.7	61.7	61.7	61.7	47.0	47.0	47.0	47.0	47.0								
8.0	56.2	56.2	56.2	56.2	56.2	45.0	45.0	45.0	45.0	45.0								
9.0	50.4	50.4	50.4	50.4	50.4	41.0	41.0	41.0	41.0	41.0	30.0	30.0	30.0	30.0	30.0			
10.0	45.5	45.5	45.5	44.8	42.6	37.3	37.3	37.3	37.3	37.3	30.0	30.0	30.0	30.0	30.0			
11.0	41.4	41.4	41.4	37.7	35.0	34.6	34.6	34.6	34.6	34.6	30.0	30.0	30.0	30.0	30.0			
12.0	37.9	37.9	37.9	32.2	29.3	32.1	32.1	32.1	32.1	30.6	28.5	28.5	28.5	28.5	28.5			
14.0	32.2	32.2	29.6	24.3	21.3	28.2	28.2	28.2	25.4	22.5	24.6	24.6	24.6	24.6	23.4			
16.0	27.8	27.8	23.4	18.9	15.8	25.0	25.0	24.5	19.9	16.9	21.4	21.4	21.4	20.8	17.8			
18.0	24.4	24.4	18.8	14.9	11.9	21.9	21.9	19.8	15.9	12.9	19.0	19.0	19.0	16.7	13.7			
20.0	21.4	19.8	15.4	11.7	9.0	19.2	19.2	16.3	12.7	10.0	17.0	17.0	17.0	13.5	10.7			
22.0	18.9	16.5	12.7	9.2	6.6	17.0	17.0	13.6	10.2	7.7	15.3	15.3	14.2	10.9	8.4			
24.0	16.9	13.8	10.5	7.1	4.5	15.1	14.7	11.3	8.1	5.7	13.8	13.8	12.0	8.8	6.5			
26.0	14.6	11.7	8.7	5.2		13.5	12.5	9.5	6.3	3.9	12.5	12.5	10.1	7.1	4.8			
28.0	12.6	9.9	7.1			12.1	10.7	8.0	4.7		11.2	11.2	8.6	5.5	3.3			
30.0						10.9	9.1	6.5	3.3		10.0	9.7	7.2	4.1	2.0			
32.0						9.8	7.8	5.1			9.0	8.4	5.9					
34.0						8.8	6.6	3.9			8.1	7.2	4.6					
36.0						7.7	5.4	2.9			7.3	6.0	3.5					
38.0						6.0	4.4				6.5	5.0						
40.0											5.9	4.0						
42.0											5.2	3.2						
44.0											4.4	2.4						
46.0											3.6	1.8						
47.0											3.3	1.5						
危険角度	10°		15°		25°	10°		20°		30°	40°		10°		15°	30°	45°	52°
標準フック	120tフック					50tフック					50tフック							
フック重量	1,300kg					1,000kg					1,000kg							
巻掛本数	8					6					4							

NK-1600-V

# KATO NK-1600-V

■作業範囲図

●スーパーラフィング

- Ⓐ 50mブーム+10.5mS.Lジブ (オフセット0°)
- Ⓑ 50mブーム+18.9mS.Lジブ (オフセット0°)
- Ⓒ 50mブーム+27.3mS.Lジブ (オフセット0°)
- Ⓓ 50mブーム+10.5mS.Lジブ (オフセット45°)
- Ⓔ 50mブーム+18.9mS.Lジブ (オフセット45°)
- Ⓕ 50mブーム+27.3mS.Lジブ (オフセット45°)

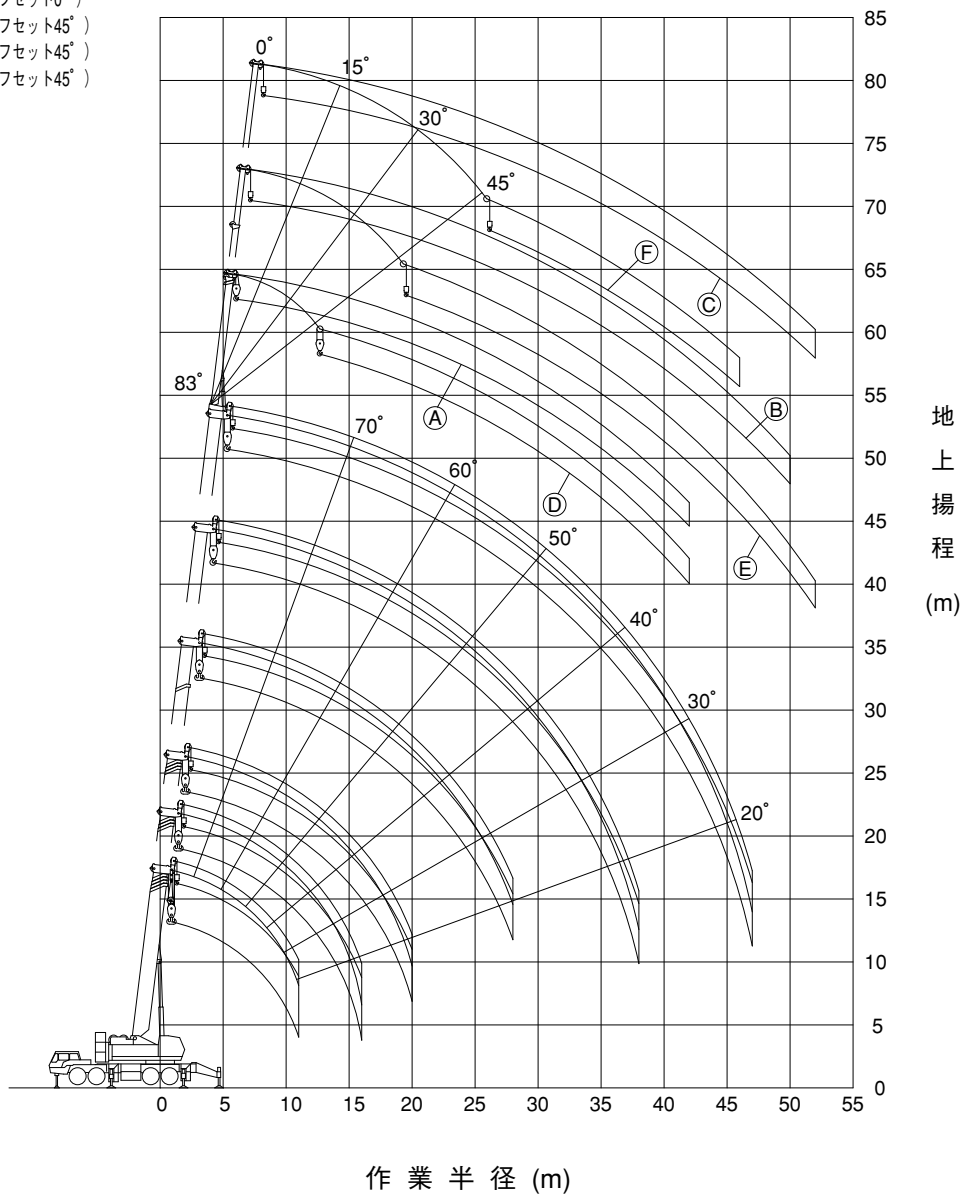

(注) 本図はブーム、ジブのたわみを含んでいません。

縮尺 1/600

作業時全装備重量 (t)	約134 (50mブーム+27.3SLジブ)
--------------	------------------------

# KATO NK-1600-V

■定格総荷重表

●50mブーム+10.5mスーパーラフィングジブ

(単位:t)

作業半径 (m)	オフセット角 0°								オフセット角 15°							
	A		B		C		D		A		B		C		D	
	ブーム 角度	荷重	ブーム 角度	荷重	ブーム 角度	荷重	ブーム 角度	荷重	ブーム 角度	荷重	ブーム 角度	荷重	ブーム 角度	荷重	ブーム 角度	荷重
14	77.7	16.00	77.7	16.00	77.7	16.00	77.7	16.00	80.0	13.60	80.0	13.60	80.0	13.60	80.0	13.60
16	76.0	14.50	76.0	14.50	76.0	14.50	76.0	14.50	78.2	12.20	78.2	12.20	78.2	12.20	78.2	12.20
18	74.5	13.00	74.5	13.00	74.5	13.00	74.5	13.00	76.4	10.95	76.4	10.95	76.4	10.95	76.4	10.95
20	72.3	11.50	72.3	11.50	72.3	11.50	72.2	10.70	74.5	9.90	74.5	9.90	74.5	9.90	74.5	9.90
22	70.3	10.20	70.3	10.20	70.3	10.20	70.2	8.40	72.6	8.95	72.6	8.95	72.6	8.95	72.6	8.95
24	68.3	8.90	68.3	8.90	68.3	8.90	68.0	6.20	70.7	8.15	70.7	8.15	70.7	8.15	70.7	7.50
26	66.2	7.80	66.2	7.80	66.2	7.80			68.5	7.40	68.5	7.40	68.5	7.40	68.5	5.55
28	64.1	6.85	64.1	6.85	64.1	6.00			66.4	6.60	66.4	6.60	66.4	6.60		
30	61.9	6.05	61.9	6.05	61.7	4.45			64.2	5.85	64.2	5.85	63.8	5.45		
32	59.7	5.25	59.7	5.25	59.4	3.00			62.0	5.20	62.0	5.20	61.4	3.95		
34	57.4	4.45	57.4	4.45					59.7	4.60	59.7	4.60				
36	55.1	3.75	54.9	3.15					57.3	4.05	57.3	3.90				
38	52.6	3.15	52.2	2.05					54.8	3.50	54.1	2.70				
40	50.1	2.65							52.3	3.00						
42	47.5	2.20							49.6	2.50						
危険角度	42°		51°		59°		66°		43°		52°		60°		67°	
標準フック	16tフック															
フック重量	650kg															
巻掛本数	2															

作業半径 (m)	オフセット角 30°								オフセット角 45°							
	A		B		C		D		A		B		C		D	
	ブーム 角度	荷重	ブーム 角度	荷重	ブーム 角度	荷重	ブーム 角度	荷重	ブーム 角度	荷重	ブーム 角度	荷重	ブーム 角度	荷重	ブーム 角度	荷重
16	80.1	9.40	80.1	9.40	80.1	9.40	80.1	9.40								
18	78.3	8.90	78.3	8.90	78.3	8.90	78.3	8.90	79.8	5.80	79.8	5.80	79.8	5.80	79.8	5.80
20	76.5	8.40	76.5	8.40	76.5	8.40	76.5	8.40	77.9	5.70	77.9	5.70	77.9	5.70	77.9	5.70
22	74.5	7.70	74.5	7.70	74.5	7.70	74.5	7.70	76.0	5.60	76.0	5.60	76.0	5.60	76.0	5.60
24	72.5	7.10	72.5	7.10	72.5	7.10	72.5	7.10	73.9	5.50	73.9	5.50	73.9	5.50	73.9	5.50
26	70.4	6.55	70.4	6.55	70.4	6.55	70.3	6.00	71.7	5.40	71.7	5.40	71.7	5.40	71.7	5.40
28	68.3	6.10	68.3	6.10	68.3	6.10	68.2	4.70	69.5	5.30	69.5	5.30	69.5	5.30	69.5	5.30
30	66.0	5.60	66.0	5.60	66.0	5.60			67.2	5.20	67.2	5.20	67.2	5.20		
32	63.7	5.05	63.7	5.05	63.7	4.65			65.0	4.90	65.0	4.90	65.0	4.90		
34	61.4	4.50	61.4	4.50	61.2	3.25			62.5	4.50	62.5	4.50	62.3	3.55		
36	58.9	4.00	58.9	4.00					59.9	4.00	59.9	4.00				
38	56.4	3.55	56.4	3.20					57.2	3.55	57.2	3.50				
40	53.8	3.10	53.4	2.05					54.4	3.10	54.0	2.50				
42	51.0	2.60							51.5	2.60						
44	48.1	2.10														
危険角度	43°		52°		61°		67°		45°		53°		61°		67°	
標準フック	16tフック															
フック重量	650kg															
巻掛本数	2															

次頁へつづく

# KATO NK-1600-V

■定格総荷重表

●50mブーム+18.9mスーパーラフィングジブ

(単位:t)

作業半径 (m)	オフセット角 0°								オフセット角 15°							
	A		B		C		D		A		B		C		D	
	ブーム 角度	荷重	ブーム 角度	荷重	ブーム 角度	荷重	ブーム 角度	荷重	ブーム 角度	荷重	ブーム 角度	荷重	ブーム 角度	荷重	ブーム 角度	荷重
12	81.1	8.00	81.1	8.00	81.1	8.00	81.1	8.00								
14	79.6	8.00	79.6	8.00	79.6	8.00	79.6	8.00								
16	78.1	8.00	78.1	8.00	78.1	8.00	78.1	8.00								
18	76.5	8.00	76.5	8.00	76.5	8.00	76.5	8.00	80.1	7.50	80.1	7.50	80.1	7.50	80.1	7.50
20	74.9	8.00	74.9	8.00	74.9	8.00	74.9	8.00	78.5	7.00	78.5	7.00	78.5	7.00	78.5	7.00
22	73.3	8.00	73.3	8.00	73.3	8.00	73.3	8.00	76.9	6.55	76.9	6.55	76.9	6.55	76.9	6.55
24	71.6	7.50	71.6	7.50	71.6	7.50	71.6	7.50	75.3	6.15	75.3	6.15	75.3	6.15	75.3	6.15
26	69.9	7.00	69.9	7.00	69.9	7.00	69.8	6.45	73.6	5.80	73.6	5.80	73.6	5.80	73.6	5.80
28	68.1	6.55	68.1	6.55	68.1	6.55	67.9	4.85	71.8	5.35	71.8	5.35	71.8	5.35	71.8	5.35
30	66.2	5.95	66.2	5.95	66.2	5.95			70.0	4.90	70.0	4.90	70.0	4.90	70.0	4.90
32	64.4	5.35	64.4	5.35	64.3	5.15			68.1	4.50	68.1	4.50	68.1	4.50	68.1	3.85
34	62.5	4.75	62.5	4.75	62.3	3.75			66.2	4.15	66.2	4.15	66.2	4.15		
36	60.5	4.25	60.5	4.25	60.3	2.75			64.3	3.85	64.3	3.85	64.3	3.85		
38	58.5	3.75	58.5	3.75					62.3	3.55	62.3	3.55	62.0	3.00		
40	56.5	3.20	56.5	3.05					60.2	3.25	60.2	3.25				
42	54.4	2.70	54.2	2.15					58.1	2.95	58.1	2.95				
44	52.3	2.25	51.8	1.35					55.9	2.60	55.7	2.30				
46	50.1	1.80							53.6	2.20	53.3	1.50				
48	47.7	1.45							51.3	1.80						
50	45.3	1.00							48.8	1.45						
52									46.2	1.05						
危険角度	43°		51°		59°		67°		44°		52°		60°		67°	
標準フック	8tフック															
フック重量	320kg															
巻掛本数	1															

作業半径 (m)	オフセット角 30°								オフセット角 45°							
	A		B		C		D		A		B		C		D	
	ブーム 角度	荷重	ブーム 角度	荷重	ブーム 角度	荷重	ブーム 角度	荷重	ブーム 角度	荷重	ブーム 角度	荷重	ブーム 角度	荷重	ブーム 角度	荷重
22	80.0	4.55	80.0	4.55	80.0	4.55	80.0	4.55								
24	78.4	4.35	78.4	4.35	78.4	4.35	78.4	4.35	80.9	2.65	80.9	2.65	80.9	2.65	80.9	2.65
26	76.7	4.15	76.7	4.15	76.7	4.15	76.7	4.15	79.2	2.55	79.2	2.55	79.2	2.55	79.2	2.55
28	75.0	3.95	75.0	3.95	75.0	3.95	75.0	3.95	77.5	2.45	77.5	2.45	77.5	2.45	77.5	2.45
30	73.2	3.80	73.2	3.80	73.2	3.80	73.2	3.80	75.6	2.35	75.6	2.35	75.6	2.35	75.6	2.35
32	71.3	3.65	71.3	3.65	71.3	3.65	71.3	3.65	73.7	2.30	73.7	2.30	73.7	2.30	73.7	2.30
34	69.4	3.50	69.4	3.50	69.4	3.50	69.4	3.50	71.7	2.25	71.7	2.25	71.7	2.25	71.7	2.25
36	67.4	3.40	67.4	3.40	67.4	3.40			69.6	2.20	69.6	2.20	69.6	2.20	69.6	2.20
38	65.3	3.15	65.3	3.15	65.3	3.15			67.5	2.15	67.5	2.15	67.5	2.15		
40	63.1	2.95	63.1	2.95	63.1	2.95			65.2	2.10	65.2	2.10	65.2	2.10		
42	61.0	2.75	61.0	2.75					62.9	2.05	62.9	2.05	62.9	2.05		
44	58.7	2.55	58.7	2.55					60.4	2.05	60.4	2.05				
46	56.3	2.35	56.2	2.20					57.9	2.00	57.9	2.00				
48	53.9	2.15	53.5	1.35					55.2	2.00	55.0	1.70				
50	51.3	1.75							52.4	1.85						
52	48.6	1.35							49.4	1.40						
危険角度	44°		52°		61°		67°		45°		53°		61°		68°	
標準フック	8tフック															
フック重量	320kg															
巻掛本数	1															

次頁へつづ

# KATO NK-1600-V

■定格総荷重表

●50mブーム+27.3mスーパーラフィングジブ

(単位:t)

作業半径 (m)	オフセット角 0°								オフセット角 15°							
	A		B		C		D		A		B		C		D	
	ブーム 角度	荷重	ブーム 角度	荷重	ブーム 角度	荷重	ブーム 角度	荷重	ブーム 角度	荷重	ブーム 角度	荷重	ブーム 角度	荷重	ブーム 角度	荷重
14	80.8	5.00	80.8	5.00	80.8	5.00	80.8	5.00								
16	79.5	5.00	79.5	5.00	79.5	5.00	79.5	5.00								
18	78.2	5.00	78.2	5.00	78.2	5.00	78.2	5.00								
20	76.4	5.00	76.4	5.00	76.4	5.00	76.4	5.00								
22	75.3	5.00	75.3	5.00	75.3	5.00	75.3	5.00	80.0	3.65	80.0	3.65	80.0	3.65	80.0	3.65
24	73.8	5.00	73.8	5.00	73.8	5.00	73.8	5.00	78.6	3.45	78.6	3.45	78.6	3.45	78.6	3.45
26	72.3	4.80	72.3	4.80	72.3	4.80	72.3	4.80	77.2	3.25	77.2	3.25	77.2	3.25	77.2	3.25
28	70.8	4.55	70.8	4.55	70.8	4.55	70.8	4.55	75.6	3.10	75.6	3.10	75.6	3.10	75.6	3.10
30	69.2	4.25	69.2	4.25	69.2	4.25	69.2	4.25	74.1	2.95	74.1	2.95	74.1	2.95	74.1	2.95
32	67.6	4.00	67.6	4.00	67.6	4.00			72.6	2.80	72.6	2.80	72.6	2.80	72.6	2.80
34	66.0	3.75	66.0	3.75	66.0	3.75			70.8	2.70	70.8	2.70	70.8	2.70	70.8	2.70
36	64.4	3.50	64.4	3.50	64.4	3.50			69.2	2.60	69.2	2.60	69.2	2.60	69.2	2.60
38	62.6	3.30	62.6	3.30	62.5	3.15			67.6	2.50	67.6	2.50	67.6	2.50		
40	60.9	3.10	60.9	3.10					65.9	2.40	65.9	2.40	65.9	2.40		
42	59.2	2.90	59.2	2.90					64.1	2.30	64.1	2.30	64.1	2.30		
44	57.5	2.50	57.5	2.50					62.3	2.20	62.3	2.20	62.3	2.20		
46	55.6	2.10	55.6	1.95					60.4	2.10	60.4	2.10				
48	53.7	1.75	53.4	1.25					58.5	1.95	58.5	1.95				
50	51.8	1.40							56.5	1.75	56.5	1.75				
52	49.8	1.10							54.5	1.55	54.3	1.15				
54									52.4	1.20						
危険角度	46°		53°		61°		68°		46°		54°		61°		69°	
標準フック	8tフック															
フック重量	320kg															
巻掛本数	1															

作業半径 (m)	オフセット角 30°								オフセット角 45°							
	A		B		C		D		A		B		C		D	
	ブーム 角度	荷重	ブーム 角度	荷重	ブーム 角度	荷重	ブーム 角度	荷重	ブーム 角度	荷重	ブーム 角度	荷重	ブーム 角度	荷重	ブーム 角度	荷重
28	79.7	2.35	79.7	2.35	79.7	2.35	79.7	2.35								
30	78.2	2.25	78.2	2.25	78.2	2.25	78.2	2.25								
32	76.5	2.20	76.5	2.20	76.5	2.20	76.5	2.20	80.0	1.20	80.0	1.20	80.0	1.20	80.0	1.20
34	75.1	2.10	75.1	2.10	75.1	2.10	75.1	2.10	78.5	1.15	78.5	1.15	78.5	1.15	78.5	1.15
36	73.5	2.05	73.5	2.05	73.5	2.05	73.5	2.05	76.8	1.10	76.8	1.10	76.8	1.10	76.8	1.10
38	71.8	2.00	71.8	2.00	71.8	2.00	71.8	2.00	75.5	1.05	75.5	1.05	75.5	1.05	75.5	1.05
40	70.0	1.95	70.0	1.95	70.0	1.95	70.0	1.95	73.3	1.00	73.3	1.00	73.3	1.00	73.3	1.00
42	68.2	1.85	68.2	1.85	68.2	1.85			71.4	0.95	71.4	0.95	71.4	0.95	71.4	0.95
44	66.4	1.80	66.4	1.80	66.4	1.80			69.4	0.90	69.4	0.90	69.4	0.90		
46	64.4	1.75	64.4	1.75	64.4	1.75			67.4	0.90	67.4	0.90	67.4	0.90		
48	62.4	1.65	62.4	1.65												
50	60.4	1.60	60.4	1.60												
52	58.3	1.50	58.3	1.50												
54	56.0	1.35	56.0	1.35												
56	53.7	1.25														
危険角度	46°		55°		62°		69°		46°		56°		63°		70°	
標準フック	8tフック															
フック重量	320kg															
巻掛本数	1															

NK-1600-V

# KATO NK-1600-V

■作業範囲図

●ヘビーリフトジブ

- ① 13.6mブーム+12mヘビーリフトジブ (オフセット10°)
- ② 13.6mブーム+21mヘビーリフトジブ (オフセット10°)
- ③ 13.6mブーム+30mヘビーリフトジブ (オフセット10°)
- ④ 13.6mブーム+12mヘビーリフトジブ (オフセット60°)
- ⑤ 13.6mブーム+21mヘビーリフトジブ (オフセット60°)
- ⑥ 13.6mブーム+30mヘビーリフトジブ (オフセット60°)
- ⑦ 50mブーム+12mヘビーリフトジブ (オフセット10°)
- ⑧ 50mブーム+21mヘビーリフトジブ (オフセット10°)
- ⑨ 50mブーム+30mヘビーリフトジブ (オフセット10°)
- ⑩ 50mブーム+38mヘビーリフトジブ (オフセット10°)
- ⑪ 50mブーム+45mヘビーリフトジブ (オフセット10°)
- ⑫ 50mブーム+12mヘビーリフトジブ (オフセット60°)
- ⑬ 50mブーム+21mヘビーリフトジブ (オフセット60°)
- ⑭ 50mブーム+30mヘビーリフトジブ (オフセット60°)
- ⑮ 50mブーム+38mヘビーリフトジブ (オフセット60°)
- ⑯ 50mブーム+45mヘビーリフトジブ (オフセット60°)

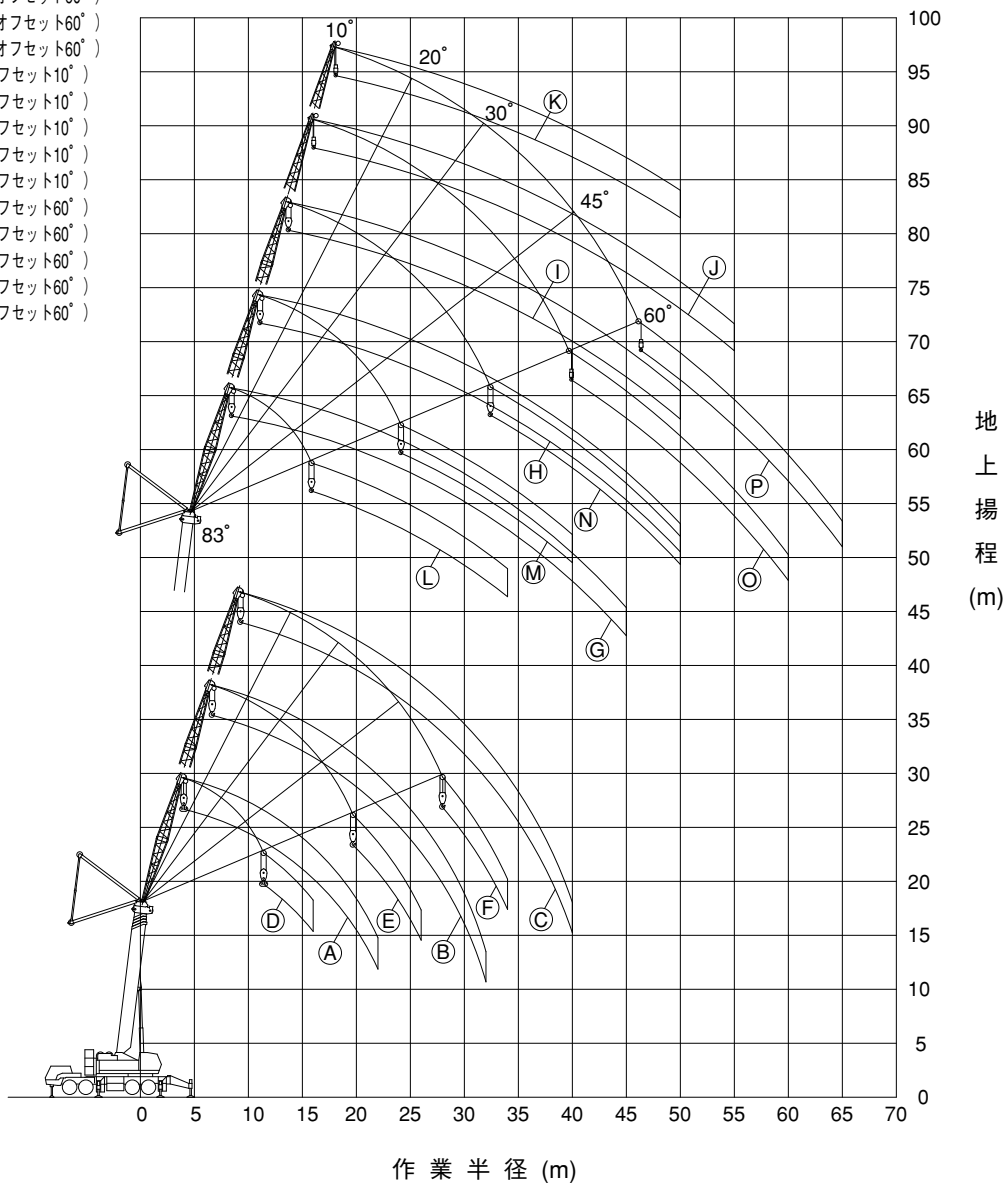

(注) 本図はブーム、ジブのたわみを含んでいません。

縮尺 1/700

作業時全装備重量 (t)	約134.8 (50mブーム+45mヘビーリフトジブ)
--------------	-----------------------------



# KATO NK-1600-V

■定格総荷重表

●13.6mブーム+12mヘビーリフトジブ

(単位:t)

作業半径 (m)	オフセット角																			
	10°				20°				30°				45°				60°			
	A	B	C	D	A	B	C	D	A	B	C	D	A	B	C	D	A	B	C	D
6	75.0	75.0	75.0	75.0																
7	74.3	74.3	74.3	74.3																
8	71.6	71.6	71.6	61.0	60.2	60.2	60.2	60.2												
9	66.3	66.3	66.3	51.3	56.6	56.6	56.6	52.8												
10	61.7	61.7	60.7	44.0	53.4	53.4	53.4	45.3	47.2	47.2	47.2	46.5								
11	57.8	57.8	51.9	38.3	50.5	50.5	50.5	39.4	45.1	45.1	45.1	40.5								
12	54.3	54.3	45.2	33.7	48.0	48.0	46.3	34.7	43.2	43.2	43.2	35.7	35.2	35.2	35.2	35.2				
14	47.0	44.2	35.4	26.9	43.7	43.7	36.3	27.6	40.0	40.0	37.1	28.4	33.1	33.1	33.1	29.3	25.9	25.9	25.9	25.9
16	40.3	35.7	28.7	22.0	40.2	36.4	29.4	22.4	37.4	37.0	30.0	23.1	31.5	31.5	30.7	23.8	25.3	25.3	25.3	24.3
18	34.0	29.6	23.9	18.3	34.5	30.1	24.3	18.8	35.0	30.6	24.8	19.2	30.4	30.4	25.3	19.7				
20	28.8	25.0	20.2	15.5	29.2	25.4	20.5	15.8	29.5	25.7	20.8	16.1	29.8	25.9	21.0	16.3				
22	24.9	21.5	17.3	13.3	25.1	21.7	17.5	13.5	25.2	21.8	17.6	13.6								
危険角度	10°				20°				30°				45°				60°			
標準フック	120tフック																			
フック重量	1,300kg																			
巻掛本数	10																			

●13.6mブーム+21mヘビーリフトジブ

(単位:t)

作業半径 (m)	オフセット角																			
	10°				20°				30°				45°				60°			
	A	B	C	D	A	B	C	D	A	B	C	D	A	B	C	D	A	B	C	D
9	47.0	47.0	47.0	47.0																
10	47.0	47.0	47.0	46.5																
11	45.6	45.6	45.6	40.7																
12	44.3	44.3	44.3	36.0																
14	38.8	38.8	37.8	29.0	33.9	33.9	33.9	30.2												
16	34.5	34.5	30.9	24.0	30.7	30.7	30.7	25.0	27.6	27.6	27.6	26.0								
18	31.1	31.1	25.9	20.2	28.0	28.0	26.8	21.0	25.5	25.5	25.5	21.9								
20	28.3	27.0	22.1	17.2	25.8	25.8	22.8	18.0	23.8	23.8	23.6	18.7	19.2	19.2	19.2	19.2				
22	25.9	23.3	19.0	14.9	24.0	24.0	19.7	15.5	22.3	22.3	20.3	16.1	18.3	18.3	18.3	17.0	14.3	14.3	14.3	14.3
24	23.5	20.4	16.6	13.0	22.4	21.0	17.2	13.5	21.0	21.0	17.7	14.0	17.5	17.5	17.5	14.7	13.9	13.9	13.9	13.9
26	20.8	18.0	14.6	11.4	21.0	18.4	15.1	11.8	19.9	18.9	15.5	12.2	16.8	16.8	16.0	12.7	13.7	13.7	13.7	13.1
28	18.5	16.0	12.9	10.0	18.9	16.3	13.3	10.4	19.0	16.7	13.6	10.7	16.4	16.4	14.0	11.1				
30	16.6	14.3	11.5	8.9	16.9	14.5	11.8	9.1	17.1	14.8	12.0	9.4								
32	15.0	12.8	10.3	7.9	15.1	13.0	10.4	8.0												
危険角度	10°				20°				30°				45°				60°			
標準フック	50tフック																			
フック重量	1,000kg																			
巻掛本数	6																			

●13.6mブーム+30mヘビーリフトジブ

(単位:t)

作業半径 (m)	オフセット角																			
	10°				20°				30°				45°				60°			
	A	B	C	D	A	B	C	D	A	B	C	D	A	B	C	D	A	B	C	D
14	26.1	26.1	26.1	26.1																
16	24.5	24.5	24.5	24.5																
18	23.1	23.1	23.1	21.3	21.7	21.7	21.7	21.7												
20	21.9	21.9	21.9	18.3	20.6	20.6	20.6	19.2												
22	20.8	20.8	20.1	15.9	19.7	19.7	19.7	16.7	18.8	18.8	18.8	17.6								
24	19.8	19.8	17.6	13.9	18.9	18.9	18.4	14.7	17.6	17.6	17.6	15.4								
26	19.0	19.0	15.6	12.3	17.8	17.8	16.3	12.9	16.5	16.5	16.5	13.6								
28	17.9	17.0	13.9	10.9	16.7	16.7	14.5	11.5	15.6	15.6	15.1	12.1	12.6	12.6	12.6	12.6				
30	16.7	15.2	12.4	9.7	15.7	15.7	13.0	10.2	14.8	14.8	13.5	10.7	12.1	12.1	12.1	11.5	9.4	9.4	9.4	9.4
32	15.6	13.7	11.2	8.7	14.8	14.2	11.6	9.1	14.0	14.0	12.1	9.6	11.6	11.6	11.6	10.2	9.1	9.1	9.1	9.1
34	14.5	12.4	10.1	7.8	14.0	12.8	10.5	8.2	13.4	13.3	10.9	8.6	11.1	11.1	11.1	9.1	8.9	8.9	8.9	8.9
36	13.2	11.3	9.1	7.0	13.3	11.7	9.5	7.3	12.8	12.0	9.8	7.7	10.8	10.8	10.2	8.1				
38	12.1	10.3	8.3	6.3	12.4	10.6	8.5	6.6	12.3	10.8	8.8	6.8	10.6	10.6	9.1	7.1				
40	11.1	9.4	7.5	5.7	11.3	9.6	7.7	5.9	11.5	9.8	7.9	6.0								
危険角度	10°				20°				30°				45°				60°			
標準フック	50tフック																			
フック重量	1,000kg																			
巻掛本数	4																			

NK-1600-V

# KATO NK-1600-V

■定格総荷重表

●18.15mブーム+12mヘビーリフトジブ

(単位:t)

作業半径 (m)	オフセット角																			
	10°				20°				30°				45°				60°			
	A	B	C	D	A	B	C	D	A	B	C	D	A	B	C	D	A	B	C	D
7	64.0	64.0	64.0	64.0																
8	62.8	62.8	62.8	59.3																
9	61.6	61.6	61.6	49.6	59.9	59.9	59.9	51.6												
10	60.4	60.4	58.8	42.4	56.8	56.8	56.8	44.0												
11	56.1	56.1	50.1	36.7	54.1	54.1	51.8	38.2	47.1	47.1	47.1	39.5								
12	52.3	52.3	43.4	32.2	51.6	51.6	44.9	33.4	45.4	45.4	45.4	34.7	38.7	38.7	38.7	36.3				
14	46.1	42.4	33.7	25.3	46.2	43.6	34.8	26.4	42.3	42.3	35.9	27.3	36.6	36.6	36.6	28.6	28.2	28.2	28.2	28.2
16	39.1	33.9	27.8	20.5	40.0	34.8	27.9	21.3	39.7	35.7	28.8	22.0	34.9	34.9	29.8	23.0	27.8	27.8	27.8	23.6
18	32.2	27.8	22.2	16.8	33.0	28.6	22.9	17.5	33.7	29.2	23.5	18.1	33.6	30.1	24.3	18.8	27.4	27.4	24.8	19.2
20	27.1	23.3	18.5	14.0	27.7	23.9	19.1	14.5	28.2	24.4	19.6	15.0	28.8	25.0	20.1	15.5				
22	23.1	19.7	15.6	11.7	23.6	20.2	16.0	12.1	24.0	20.6	16.4	12.4	24.3	20.9	16.7	12.8				
24	19.9	16.9	13.2	9.8	20.3	17.2	13.6	10.1	20.5	17.5	13.8	10.4								
26	17.3	14.6	11.3	8.3	17.5	14.8	11.5	8.5	17.6	14.9	11.6	8.6								
28	14.4	12.6	9.8	7.0																
危険角度	10°				20°				30°				45°				60°			
標準フック	120tフック																			
フック重量	1,300kg																			
巻掛本数	8																			

●18.15mブーム+21mヘビーリフトジブ

(単位:t)

作業半径 (m)	オフセット角																			
	10°				20°				30°				45°				60°			
	A	B	C	D	A	B	C	D	A	B	C	D	A	B	C	D	A	B	C	D
10	44.0	44.0	44.0	44.0																
11	43.5	43.5	43.5	39.3																
12	42.9	42.9	42.9	34.7																
14	41.8	41.8	36.3	27.6	35.7	35.7	35.7	29.2												
16	37.8	36.5	29.4	22.6	32.6	32.6	30.9	23.9	28.6	28.6	28.6	25.3								
18	34.2	30.2	24.4	18.8	29.9	29.9	25.7	20.0	26.6	26.6	26.6	21.1								
20	29.3	25.5	20.6	15.9	27.7	26.6	21.6	16.9	25.0	25.0	22.7	17.8	20.8	20.8	20.8	19.1				
22	25.2	21.8	17.6	13.5	25.8	22.8	18.5	14.4	23.5	23.5	19.4	15.2	19.8	19.8	19.8	16.3	15.5	15.5	15.5	15.5
24	21.9	18.9	15.2	11.6	22.7	19.7	15.9	12.3	22.3	20.4	16.7	13.0	19.0	19.0	17.7	14.0	15.1	15.1	15.1	14.7
26	19.3	16.5	13.2	10.0	19.9	17.2	13.8	10.6	20.6	17.8	14.4	11.2	18.3	18.3	15.3	12.0	14.8	14.8	14.8	12.6
28	17.0	14.5	11.5	8.7	17.6	15.1	12.0	9.2	18.1	15.6	12.6	9.7	17.8	16.3	13.2	10.3	14.6	14.6	13.6	10.7
30	15.1	12.8	10.1	7.5	15.6	13.3	10.5	7.9	16.0	13.7	10.9	8.3	16.5	14.2	11.4	8.8				
32	13.5	11.3	8.9	6.5	13.9	11.7	9.2	6.9	14.2	12.0	9.5	7.2	14.5	12.4	9.8	7.5				
34	12.1	10.1	7.8	5.6	12.4	10.4	8.1	5.9	12.6	10.6	8.3	6.1								
36	10.9	9.0	6.9	4.7	11.1	9.2	7.0	4.9												
危険角度	10°				20°				30°				45°				60°			
標準フック	50tフック																			
フック重量	1,000kg																			
巻掛本数	6																			

●18.15mブーム+30mヘビーリフトジブ

(単位:t)

作業半径 (m)	オフセット角																							
	10°				20°				30°				45°				60°							
	A	B	C	D	A	B	C	D	A	B	C	D	A	B	C	D	A	B	C	D				
14	25.5	25.5	25.5	25.5																				
16	24.7	24.7	24.7	24.0																				
18	24.0	24.0	24.0	20.2	21.7	21.7	21.7	21.6																
20	22.8	22.8	22.0	17.2	21.2	21.2	21.2	18.5																
22	21.7	21.7	18.9	14.8	20.3	20.3	20.1	15.9	19.1	19.1	19.1	17.0												
24	20.8	20.2	16.5	12.8	19.5	19.5	17.5	13.8	18.3	18.3	18.3	14.8												
26	19.9	17.8	14.4	11.2	18.8	18.8	15.3	12.0	17.2	17.2	16.3	12.9												
28	18.3	15.7	12.7	9.8	17.8	16.6	13.5	10.6	16.3	16.3	14.3	11.3	13.7	13.7	13.7	12.5								
30	16.3	14.0	11.2	8.6	16.7	14.7	12.0	9.3	15.5	15.5	12.7	10.0	13.1	13.1	13.1	11.0								
32	14.7	12.5	10.0	7.5	15.3	13.2	10.6	8.2	14.8	13.8	11.3	8.8	12.6	12.6	12.2	9.7	9.9	9.9	9.9	9.9				
34	13.2	11.2	8.9	6.6	13.8	11.8	9.4	7.2	14.1	12.4	10.0	7.7	12.2	12.2	10.8	8.5	9.7	9.7	9.7	9.1				
36	12.0	10.1	7.9	5.9	12.5	10.6	8.4	6.3	13.0	11.1	8.9	6.8	11.8	11.8	9.6	7.4	9.5	9.5	9.5	7.9				
38	10.9	9.1	7.1	5.1	11.3	9.5	7.5	5.6	11.7	9.9	7.9	6.0	11.5	10.5	8.4	6.5								
40	9.9	8.2	6.3	4.4	10.2	8.6	6.7	4.9	10.6	8.9	7.0	5.2	11.0	9.3	7.4	5.6								
45	7.8	6.3																						
危険角度	10°				25°		30°		20°		30°		35°		30°		35°		40°		45°		60°	
標準フック	50tフック																							
フック重量	1,000kg																							
巻掛本数	4																							

# KATO NK-1600-V

■定格総荷重表

●22.7mブーム+12mヘビーリフトジブ

(単位:t)

作業半径 (m)	オフセット角																															
	10°				20°				30°				45°				60°															
	A	B	C	D	A	B	C	D	A	B	C	D	A	B	C	D	A	B	C	D												
8	58.0	58.0	58.0	57.9																												
9	58.0	58.0	58.0	48.3																												
10	55.0	55.0	55.0	41.1	57.0	57.0	57.0	43.0																								
11	50.1	50.1	48.6	35.4	52.0	52.0	50.6	37.1	48.8	48.8	48.8	38.7																				
12	46.0	46.0	41.9	30.9	47.6	47.6	43.7	32.4	47.1	47.1	45.3	33.8																				
14	39.1	39.1	32.3	24.1	40.5	40.5	33.6	25.3	41.9	41.9	34.9	26.4	38.0	38.0	36.6	27.9																
16	33.9	32.5	25.7	19.2	35.0	33.6	26.8	20.2	36.1	34.7	27.8	21.1	36.5	36.0	29.1	22.3	29.2	29.2	29.2	23.2												
18	29.6	26.4	20.9	15.6	30.5	27.4	21.7	16.4	31.5	28.2	22.6	17.1	32.8	29.3	23.6	18.1	28.7	28.7	24.2	18.7												
20	25.7	21.9	17.2	12.8	26.5	22.7	17.9	13.4	27.2	23.3	18.6	14.0	28.0	24.2	19.3	14.8	28.3	24.6	19.8	15.1												
22	21.8	18.4	14.3	10.5	22.4	19.0	14.9	11.0	22.9	19.6	15.4	11.5	23.5	20.2	16.0	12.1																
24	18.6	15.6	12.0	8.6	19.1	16.1	12.5	9.1	19.5	16.5	12.9	9.5	20.0	16.9	13.3	9.9																
26	16.0	13.2	10.1	7.0	16.4	13.6	10.4	7.4	16.7	14.0	10.8	7.8	17.0	14.2	11.0	8.0																
28	13.9	11.3	8.5	5.5	14.2	11.6	8.7	5.9	14.4	11.8	9.0	6.1																				
30	12.0	9.7	7.0	4.2	12.2	9.9	7.2	4.4	12.3	10.0	7.3	4.5																				
32	10.5	8.3	5.7		10.6	8.4	5.8																									
危険角度	10°				25°				20°				25°				30°				31°				45°				60°			
標準フック	120tフック																															
フック重量	1,300kg																															
巻掛本数	8																															

●22.7mブーム+21mヘビーリフトジブ

(単位:t)

作業半径 (m)	オフセット角																																			
	10°				20°				30°				45°				60°																			
	A	B	C	D	A	B	C	D	A	B	C	D	A	B	C	D	A	B	C	D																
11	41.0	41.0	41.0	38.3																																
12	41.0	41.0	41.0	33.6																																
14	40.0	40.0	35.1	26.6	37.3	37.3	37.3	28.5																												
16	36.3	35.2	28.3	21.5	34.2	34.2	30.0	23.1																												
18	31.9	29.0	23.3	17.8	31.6	30.5	24.7	19.1	27.6	27.6	26.2	20.4																								
20	28.1	24.3	19.4	14.8	29.4	25.6	20.7	16.0	26.0	26.0	21.9	17.1																								
22	24.0	20.6	16.4	12.5	25.2	21.8	17.5	13.5	24.6	22.9	18.6	14.5	20.9	20.9	20.0	15.8																				
24	20.8	17.7	14.0	10.5	21.7	18.7	15.0	11.4	22.7	19.6	15.9	12.3	20.1	20.1	17.1	13.4	15.9	15.9	15.9	14.3																
26	18.1	15.3	12.0	8.9	18.9	16.2	12.8	9.7	19.7	17.0	13.6	10.5	19.4	18.0	14.7	11.4	15.5	15.5	15.4	12.2																
28	15.8	13.3	10.4	7.6	16.6	14.0	11.1	8.3	17.3	14.7	11.7	8.9	18.2	15.6	12.6	9.7	15.3	15.3	13.2	10.3																
30	13.9	11.6	8.9	6.4	14.6	12.2	9.5	7.0	15.2	12.8	10.1	7.6	15.9	13.6	10.8	8.2	15.2	14.0	11.2	8.6																
32	12.3	10.2	7.7	5.3	12.9	10.7	8.2	5.9	13.4	11.2	8.7	6.4	13.9	11.8	9.3	6.9																				
34	10.9	8.9	6.6	4.2	11.4	9.4	7.1	4.8	11.8	9.8	7.5	5.2	12.2	10.2	7.9	5.7																				
36	9.7	7.8	5.6	3.3	10.1	8.2	6.0	3.7	10.4	8.5	6.4	4.1																								
38	8.6	6.9	4.6	2.4	8.9	7.1	5.0	2.8	9.1	7.3	5.2	3.0																								
40	7.7	5.9	3.7		7.9	6.1	4.0																													
危険角度	10°				20°				25°				32°				30°				30°				32°				45°				60°			
標準フック	50tフック																																			
フック重量	1,000kg																																			
巻掛本数	6																																			

●22.7mブーム+30mヘビーリフトジブ

(単位:t)

作業半径 (m)	オフセット角																			
	10°				20°				30°				45°				60°			
	A	B	C	D	A	B	C	D	A	B	C	D	A	B	C	D	A	B	C	D
14	25.0	25.0	25.0	25.0																
16	24.3	24.3	24.3	23.1																
18	23.7	23.7	23.7	19.3																
20	23.0	23.0	21.0	16.3	21.0	21.0	21.0	17.8												
22	22.0	22.0	18.0	13.8	20.2	20.2	19.4	15.2												
24	21.0	19.2	15.5	11.9	19.5	19.5	16.8	13.1	18.2	18.2	18.0	14.3								
26	19.5	16.8	13.4	10.2	18.8	17.9	14.6	11.3	17.4	17.4	15.7	12.4								
28	17.2	14.7	11.7	8.8	18.2	15.8	12.7	9.8	16.6	16.6	13.7	10.8	14.4	14.4	14.4	12.1				
30	15.3	13.0	10.2	7.6	16.2	13.9	11.1	8.5	15.8	14.8	12.0	9.4	13.8	13.8	13.3	10.6				
32	13.6	11.5	9.0	6.6	14.5	12.3	9.8	7.4	15.1	13.1	10.6	8.1	13.3	13.3	11.7	9.2	10.4	10.4	10.4	10.1
34	12.2	10.2	7.9	5.7	12.9	10.9	8.6	6.4	13.7	11.7	9.3	7.1	12.9	12.7	10.3	8.0	10.2	10.2	10.2	8.8
36	10.9	9.0	6.9	4.8	11.6	9.7	7.6	5.5	12.3	10.4	8.2	6.1	12.5	11.2	9.0	7.0	10.0	10.0	9.7	7.6
38	9.8	8.0	6.1	3.9	10.4	8.6	6.6	4.6	11.0	9.2	7.2	5.3	11.7	10.0	7.9	6.0	9.9	9.9	8.4	6.4
40	8.8	7.2	5.2	3.1	9.4	7.7	5.8	3.8	9.9	8.2	6.3	4.4	10.5	8.8	6.9	5.1				
45	6.8	5.2	3.3		7.1	5.6	3.8		7.4	6.0	4.2									
50	5.1																			
危険角度	10°	23°	25°	30°	20°	25°	33°	35°	30°	38°	40°		45°		46°		60°			
標準フック	50tフック																			
フック重量	1,000kg																			
巻掛本数	4																			

NK-1600-V

# KATO NK-1600-V

■定格総荷重表

●31.8mブーム+12mヘビーリフトジブ

(単位:t)

作業半径 (m)	オフセット角																																							
	10°				20°				30°				45°				60°																							
	A	B	C	D	A	B	C	D	A	B	C	D	A	B	C	D	A	B	C	D																				
10	38.0	38.0	38.0	38.0																																				
11	38.0	38.0	38.0	35.5																																				
12	36.3	36.3	36.3	31.0	33.0	33.0	33.0	32.5																																
14	32.2	32.2	32.2	24.2	31.0	31.0	31.0	25.4	28.0	28.0	28.0	26.6																												
16	28.0	28.0	25.8	19.3	29.1	29.1	26.9	20.3	28.0	28.0	28.0	21.3	27.2	27.2	27.2	22.5																								
18	24.5	24.5	20.9	15.7	25.4	25.4	21.9	16.5	26.3	26.3	22.8	17.3	26.9	26.9	23.9	18.4	23.2	23.2	23.2	19.0																				
20	21.6	21.6	17.3	12.8	22.4	22.4	18.1	13.6	23.1	23.1	18.8	14.3	24.2	24.2	19.7	15.1	23.2	23.2	20.3	15.6																				
22	19.1	18.5	14.4	10.6	19.8	19.2	15.1	11.2	20.4	19.8	15.7	11.8	21.3	20.6	16.4	12.5	22.1	21.0	16.8	12.9																				
24	17.1	15.6	12.0	8.7	17.7	16.2	12.6	9.3	18.2	16.8	13.1	9.7	18.9	17.4	13.7	10.3	19.5	17.7	14.0	10.6																				
26	15.3	13.3	10.1	7.1	15.8	13.8	10.6	7.6	16.3	14.3	11.1	8.0	16.8	14.8	11.5	8.5	17.2	15.0	11.7	8.7																				
28	13.7	11.4	8.5	5.6	14.2	11.8	8.9	6.1	14.6	12.2	9.3	6.5	15.0	12.6	9.7	7.0																								
30	12.1	9.7	7.0	4.2	12.5	10.1	7.5	4.7	12.8	10.4	7.8	5.1	13.1	10.7	8.1	5.4																								
32	10.5	8.3	5.7	3.0	10.8	8.7	6.1	3.4	11.1	8.9	6.4	3.8	11.3	9.1	6.6	4.0																								
34	9.2	7.0	4.5		9.4	7.4	4.8		9.6	7.6	5.0																													
36	8.0	5.9	3.4		8.2	6.1	3.6		8.3	6.3	3.8																													
38	6.8	4.7			7.0	4.9			7.1	5.0																														
40	5.8	3.7			5.9	3.8																																		
危険角度	10°				25°				35°				20°				25°				35°				30°				35°				45°				60°			
標準フック	50tフック																																							
フック重量	1,000kg																																							
巻掛本数	6																																							

●31.8mブーム+21mヘビーリフトジブ

(単位:t)

作業半径 (m)	オフセット角																			
	10°				20°				30°				45°				60°			
	A	B	C	D	A	B	C	D	A	B	C	D	A	B	C	D	A	B	C	D
14	26.5	26.5	26.5	26.4																
16	25.6	25.6	25.6	21.4	24.5	24.5	24.5	23.1												
18	24.6	24.6	23.1	17.6	23.9	23.9	23.9	19.1												
20	22.3	22.3	19.3	14.7	23.2	23.2	20.6	15.9	21.7	21.7	21.7	17.1								
22	20.1	20.1	16.3	12.3	21.1	21.1	17.5	13.4	21.2	21.2	18.6	14.5								
24	18.0	17.5	13.8	10.4	18.9	18.6	14.9	11.4	19.9	19.6	15.9	12.3	18.0	18.0	17.2	13.5				
26	16.1	15.1	11.8	8.8	17.0	16.1	12.8	9.6	17.8	17.0	13.6	10.5	18.0	18.0	14.8	11.5	15.0	15.0	15.0	12.3
28	14.5	13.1	10.2	7.4	15.3	14.0	11.0	8.2	16.0	14.7	11.7	8.9	17.1	15.8	12.7	9.8	15.0	15.0	13.4	10.5
30	13.1	11.4	8.7	6.2	13.8	12.2	9.5	6.9	14.5	12.9	10.1	7.6	15.4	13.7	11.0	8.4	15.0	14.3	11.6	8.9
32	11.9	10.0	7.5	5.0	12.5	10.6	8.2	5.8	13.1	11.2	8.7	6.4	13.9	12.0	9.5	7.1	14.5	12.4	9.9	7.5
34	10.7	8.7	6.4	3.9	11.3	9.3	7.0	4.7	11.8	9.8	7.5	5.4	12.5	10.5	8.2	6.0	12.8	10.8	8.5	6.3
36	9.5	7.6	5.3	3.0	10.0	8.1	6.0	3.7	10.5	8.6	6.5	4.2	11.0	9.1	7.0	4.9				
38	8.4	6.6	4.3		8.9	7.1	4.9		9.3	7.5	5.5	3.2	9.7	7.9	5.9	3.8				
40	7.5	5.6	3.4		7.8	6.1	4.0		8.2	6.5	4.4		8.5	6.8	4.8					
45	5.3	3.5			5.6	3.8			5.8	4.0										
危険角度	15°	25°	30°	45°	20°	30°	45°	30°	35°	45°	45°	45°	45°	45°	45°	45°	60°	60°	60°	60°
標準フック	50tフック																			
フック重量	1,000kg																			
巻掛本数	4																			

●31.8mブーム+30mヘビーリフトジブ

(単位:t)

作業半径 (m)	オフセット角																			
	10°				20°				30°				45°				60°			
	A	B	C	D	A	B	C	D	A	B	C	D	A	B	C	D	A	B	C	D
16	16.0	16.0	16.0	16.0																
18	16.0	16.0	16.0	16.0																
20	16.0	16.0	16.0	16.0																
22	16.0	16.0	16.0	13.7	16.0	16.0	16.0	15.1												
24	16.0	16.0	15.3	11.7	16.0	16.0	16.0	13.0												
26	15.8	15.8	13.2	10.0	16.0	16.0	14.5	11.2	16.0	16.0	15.7	12.4								
28	15.3	14.5	11.5	8.6	15.8	15.7	12.6	9.7	16.0	16.0	13.7	10.7								
30	14.1	12.7	10.0	7.4	14.9	13.8	11.0	8.4	15.6	14.8	12.0	9.3	13.0	13.0	13.0	10.6				
32	12.8	11.2	8.7	6.4	13.7	12.2	9.7	7.3	14.5	13.1	10.5	8.1	13.0	13.0	11.8	9.3				
34	11.7	9.9	7.6	5.4	12.5	10.8	8.5	6.3	13.2	11.6	9.3	7.0	13.0	12.7	10.4	8.1	10.5	10.5	10.5	8.9
36	10.7	8.8	6.7	4.4	11.4	9.6	7.4	5.4	12.1	10.3	8.1	6.1	12.5	11.3	9.1	7.0	10.5	10.5	9.9	7.7
38	9.6	7.8	5.7	3.6	10.3	8.5	6.5	4.5	11.0	9.2	7.1	5.2	11.8	10.1	8.0	6.1	10.5	10.5	8.6	6.7
40	8.6	6.9	4.9	2.8	9.2	7.5	5.6	3.6	9.8	8.1	6.2	4.4	10.6	8.9	7.0	5.2	10.5	9.4	7.5	5.7
45	6.5	4.9	2.9		7.0	5.5	3.6		7.5	6.0	4.2	2.3	8.0	6.5	4.8	3.0				
50	4.7	3.1			5.1	3.6			5.5	4.0	2.3		5.8	4.4	2.6					
危険角度	25°	26°	30°	50°	30°	33°	50°	35°	38°	50°	45°	50°	45°	45°	50°	50°	60°	60°	60°	60°
標準フック	16tフック																			
フック重量	650kg																			
巻掛本数	2																			

次頁へつづく

# KATO NK-1600-V

■定格総荷重表

●31.8mブーム+38mヘビーリフトジブ

(単位:t)

作業半径 (m)	オフセット角																				
	10°				20°				30°				45°				60°				
	A	B	C	D	A	B	C	D	A	B	C	D	A	B	C	D	A	B	C	D	
20	8.0	8.0	8.0	8.0																	
25	8.0	8.0	8.0	8.0	8.0	8.0	8.0	8.0													
30	8.0	8.0	8.0	8.0	8.0	8.0	8.0	8.0	8.0	8.0	8.0	8.0									
35	8.0	8.0	8.0	6.3	8.0	8.0	8.0	7.2	7.5	7.5	7.5	7.5									
40	8.0	8.0	6.3	4.3	7.6	7.6	7.1	5.3	7.1	7.1	7.1	6.0	6.5	6.5	6.5	6.5					
45	7.5	6.2	4.5	2.6	7.1	6.9	5.3	3.5	6.7	6.7	5.9	4.3	6.0	6.0	6.0	5.2	5.5	5.5	5.5	5.5	
50	6.1	4.6	2.9		6.6	5.2	3.7	1.9	6.3	5.8	4.3	2.6	5.7	5.7	5.0	3.5	5.3	5.3	5.3	4.0	
55	4.6	3.1	1.6		5.1	3.7	2.2		5.5	4.2	2.7		5.4	4.8	3.3						
60	3.3	1.9			3.7	2.3			4.0	2.7											
危険角度	25°	26°	30°	50°	30°	31°	35°	50°	35°	30°	38°	50°	45°				50°	60°			
標準フック	8tフック																				
フック重量	450kg																				
巻掛本数	1																				

●31.8mブーム+45mヘビーリフトジブ

(単位:t)

作業半径 (m)	オフセット角																				
	10°				20°				30°				45°				60°				
	A	B	C	D	A	B	C	D	A	B	C	D	A	B	C	D	A	B	C	D	
20	5.6	5.6	5.6	5.6																	
25	5.6	5.6	5.6	5.6																	
30	5.3	5.3	5.3	5.3	5.0	5.0	5.0	5.0													
35	4.9	4.9	4.9	4.9	4.5	4.5	4.5	4.5	4.1	4.1	4.1	4.1									
40	4.5	4.5	4.5	4.5	4.1	4.1	4.1	4.1	3.8	3.8	3.8	3.8									
45	4.1	4.1	4.1	3.2	3.8	3.8	3.8	3.8	3.5	3.5	3.5	3.5	3.2	3.2	3.2	3.2					
50	3.8	3.8	3.2	1.8	3.5	3.5	3.5	2.7	3.3	3.3	3.3	3.3	3.1	3.1	3.1	3.1	3.0	3.0	3.0	3.0	
55	3.5	3.5	2.2		3.3	3.3	3.0	1.4	3.1	3.1	3.1	2.1	3.1	3.1	3.1	3.1	3.0	3.0	3.0	3.0	
60	3.3	2.5			3.2	3.1	1.7		3.1	3.1	2.3		3.1	3.1	3.0	1.6					
65	2.7	1.5			3.1	1.9			3.1	2.3			3.1	2.8	1.5						
危険角度	25°	26°	40°	52°	30°	31°	40°	54°	35°	42°	55°	50°	45°				56°	60°			
標準フック	8tフック																				
フック重量	450kg																				
巻掛本数	1																				

NK-1600-V

# KATO NK-1600-V

■定格総荷重表

●40.9mブーム+12mヘビーリフトジブ

(単位:t)

作業半径 (m)	オフセット角																			
	10°				20°				30°				45°				60°			
	A	B	C	D	A	B	C	D	A	B	C	D	A	B	C	D	A	B	C	D
12	21.0	21.0	21.0	21.0																
14	21.0	21.0	21.0	21.0	20.0	20.0	20.0	20.0												
16	20.1	20.1	20.1	19.4	19.2	19.2	19.2	19.2	18.4	18.4	18.4	18.4								
18	19.2	19.2	19.2	15.8	18.4	18.4	18.4	16.7	17.7	17.7	17.7	17.5	17.0	17.0	17.0	17.0	16.4	16.4	16.4	16.4
20	17.0	17.0	17.0	12.9	17.6	17.6	17.6	13.7	16.9	16.9	16.9	14.4	16.4	16.4	16.4	15.3	15.8	15.8	15.8	15.8
22	15.1	15.1	14.5	10.7	15.6	15.6	15.2	11.4	16.2	16.2	15.9	12.0	15.7	15.7	15.7	12.7	15.1	15.1	15.1	13.2
24	13.5	13.5	12.1	8.8	14.0	14.0	12.8	9.4	14.4	14.4	13.4	9.9	15.1	15.1	14.0	10.6	14.5	14.5	14.4	11.0
26	12.2	12.2	10.2	7.2	12.6	12.6	10.8	7.8	13.0	13.0	11.3	8.3	13.5	13.5	11.9	8.8	13.9	13.9	12.2	9.1
28	11.0	11.0	8.6	5.7	11.3	11.3	9.1	6.3	11.7	11.7	9.5	6.8	12.1	12.1	10.0	7.3	12.4	12.4	10.2	7.5
30	9.9	9.8	7.1	4.3	10.2	10.2	7.7	4.9	10.5	10.5	8.0	5.4	10.9	10.9	8.4	5.9	11.2	11.2	8.6	6.0
32	8.8	8.4	5.8		9.2	8.8	6.3		9.5	9.2	6.7		9.9	9.5	7.1					
34	7.8	7.1	4.6		8.2	7.5	5.0		8.5	7.8	5.4		8.8	8.1	5.7					
36	7.0	5.9	3.4		7.3	6.3	3.9		7.5	6.6	4.2		7.8	6.8	4.4					
38	6.2	4.8			6.5	5.1			6.7	5.4	3.1		6.9	5.6	3.3					
40	5.5	3.8			5.8	4.1			5.9	4.3										
45	3.5				3.7				3.7											
危険角度	25°	30°	50°	58°	28°	30°	50°	60°	33°	35°	50°	60°	45°	50°	60°				60°	
標準フック	50tフック																			
フック重量	1,000kg																			
巻掛本数	4																			

●40.9mブーム+21mヘビーリフトジブ

(単位:t)

作業半径 (m)	オフセット角																			
	10°				20°				30°				45°				60°			
	A	B	C	D	A	B	C	D	A	B	C	D	A	B	C	D	A	B	C	D
16	14.5	14.5	14.5	14.5																
18	14.5	14.5	14.5	14.5	13.5	13.5	13.5	13.5												
20	14.5	14.5	14.5	14.5	13.5	13.5	13.5	13.5												
22	14.3	14.3	14.3	12.3	13.5	13.5	13.5	13.5	13.5	13.5	13.5	13.5								
24	14.1	14.1	13.8	10.4	13.3	13.3	13.3	11.4	13.2	13.2	13.2	12.4								
26	12.9	12.9	11.8	8.7	13.1	13.1	12.8	9.7	13.0	13.0	13.0	10.6	12.5	12.5	12.5	11.7				
28	11.7	11.7	10.1	7.4	12.4	12.4	11.0	8.2	12.8	12.8	11.8	9.0	12.5	12.5	12.5	10.0	11.5	11.5	11.5	10.7
30	10.7	10.7	8.7	6.1	11.3	11.3	9.5	7.0	11.8	11.8	10.2	7.7	12.5	12.5	11.2	8.6	11.5	11.5	11.5	9.2
32	9.8	9.8	7.5	5.0	10.3	10.3	8.2	5.8	10.7	10.7	8.8	6.5	11.4	11.4	9.7	7.3	11.5	11.5	10.2	7.8
34	8.9	8.7	6.3	3.9	9.4	9.3	7.0	4.7	9.8	9.8	7.6	5.4	10.3	10.3	8.4	6.2	10.8	10.8	8.8	6.6
36	8.1	7.5	5.3		8.5	8.1	6.0		8.9	8.7	6.6	4.4	9.4	9.3	7.2	5.1	9.8	9.7	7.5	5.5
38	7.3	6.5	4.2		7.8	7.1	5.0		8.1	7.6	5.5		8.6	8.1	6.2		8.9	8.4	6.4	4.4
40	6.6	5.5	3.3		7.0	6.1	4.0		7.4	6.6	4.5		7.8	7.1	5.1		8.0			
45	5.0	3.3			5.4	3.8			5.6	4.2			5.9	4.6						
50	3.2				3.5				3.8	2.2										
危険角度	25°	30°	50°	58°	28°	30°	50°	60°	33°	35°	50°	60°	45°	50°	60°				60°	
標準フック	16tフック																			
フック重量	650kg																			
巻掛本数	2																			

●40.9mブーム+30mヘビーリフトジブ

(単位:t)

作業半径 (m)	オフセット角																			
	10°				20°				30°				45°				60°			
	A	B	C	D	A	B	C	D	A	B	C	D	A	B	C	D	A	B	C	D
18	9.0	9.0	9.0	9.0																
20	9.0	9.0	9.0	9.0																
22	9.0	9.0	9.0	9.0																
24	9.0	9.0	9.0	9.0	8.0	8.0	8.0	8.0												
26	9.0	9.0	9.0	9.0	8.0	8.0	8.0	8.0												
28	8.7	8.7	8.7	8.3	8.0	8.0	8.0	8.0	8.0	8.0	8.0	8.0								
30	8.4	8.4	8.4	7.1	8.0	8.0	8.0	8.0	8.0	8.0	8.0	8.0								
32	8.1	8.1	8.1	6.0	8.0	8.0	8.0	7.0	8.0	8.0	8.0	7.9	7.5	7.5	7.5	7.5				
34	7.8	7.8	7.3	4.9	7.8	7.8	7.8	6.0	8.0	8.0	8.0	6.8	7.5	7.5	7.5	7.5				
36	7.5	7.5	6.3	4.0	7.6	7.6	7.1	5.0	7.8	7.8	7.8	5.9	7.5	7.5	7.5	6.9	6.7	6.7	6.7	6.7
38	7.2	7.2	5.3		7.4	7.4	6.2	4.1	7.6	7.6	6.9	5.0	7.5	7.5	7.5	6.0	6.7	6.7	6.7	6.7
40	6.6	6.5	4.4		7.0	7.0	5.3		7.4	7.4	6.1	4.1	7.5	7.5	6.9	5.1	6.7	6.7	6.7	5.7
45	5.3	4.4	2.4		5.7	5.1	3.2		6.2	5.8	4.0		6.7	6.5	4.8		6.7	6.7	5.2	3.5
50	4.1	2.6			4.5	3.2			5.0	3.8			5.5	4.5	2.8					
55	2.6				3.1				3.5	2.1			3.9	2.5						
危険角度	25°	40°	50°	60°	30°	40°	52°	62°	40°	40°	52°	62°	45°	52°	62°				60°	63°
標準フック	16tフック																			
フック重量	650kg																			
巻掛本数	2																			

次頁へつづく

# KATO NK-1600-V

■定格総荷重表

●40.9mブーム+38mヘビリーフトジブ

(単位:t)

作業半径 (m)	オフセット角																			
	10°				20°				30°				45°				60°			
	A	B	C	D	A	B	C	D	A	B	C	D	A	B	C	D	A	B	C	D
20	6.0	6.0	6.0	6.0																
25	6.0	6.0	6.0	6.0	6.0	6.0	6.0	6.0												
30	6.0	6.0	6.0	6.0	6.0	6.0	6.0	6.0												
35	5.8	5.8	5.8	5.8	5.85	5.85	5.85	5.85	6.0	6.0	6.0	6.0								
40	5.6	5.6	5.6	3.8	5.7	5.7	5.7	5.0	5.8	5.8	5.8	5.5	5.9	5.9	5.9	5.9				
45	5.4	5.4	4.0		5.5	5.5	5.0		5.6	5.6	5.6	4.1	5.7	5.7	5.7	5.1	5.0	5.0	5.0	5.0
50	4.6	4.1	2.4		4.95	4.9	3.3		5.3	5.3	4.1		5.5	5.5	4.9		5.0	5.0	5.0	4.1
55	3.7	2.6			4.1	3.3			4.5	4.0	2.5		5.0	4.7	3.3		5.0	5.0	3.7	
60	2.8	1.4			3.2	2.0			3.6	2.5			4.0	3.1						
65	1.6				2.1				2.4				2.8	1.5						
危険角度	25°	41°	51°	60°	30°	41°	53°	62°	35°	42°	53°	62°	45°	53°	62°		60°			63°
標準フック	8tフック																			
フック重量	450kg																			
巻掛本数	1																			

●40.9mブーム+45mヘビリーフトジブ

(単位:t)

作業半径 (m)	オフセット角																			
	10°				20°				30°				45°				60°			
	A	B	C	D	A	B	C	D	A	B	C	D	A	B	C	D	A	B	C	D
25	4.0	4.0	4.0	4.0																
30	4.0	4.0	4.0	4.0	4.0	4.0	4.0	4.0												
35	4.0	4.0	4.0	4.0	4.0	4.0	4.0	4.0												
40	4.0	4.0	4.0	4.0	4.0	4.0	4.0	4.0	3.8	3.8	3.8	3.8								
45	4.0	4.0	4.0		3.8	3.8	3.8		3.6	3.6	3.6	3.6	3.2	3.2	3.2	3.2				
50	3.7	3.7	3.0		3.6	3.6	3.6		3.4	3.4	3.4		3.1	3.1	3.1	3.1	2.9	2.9	2.9	2.9
55	3.4	3.2			3.4	3.4	2.5		3.2	3.2	3.2		3.0	3.0	3.0		2.9	2.9	2.9	2.9
60	2.8	1.9			3.1	2.7			3.1	3.1	2.0		3.0	3.0	2.9		2.9	2.9	2.9	
65	2.1				2.6	1.5			2.9	2.1			3.0	2.8						
70					1.7				2.1				2.5	1.4						
危険角度	33°	45°	53°	62°	33°	46°	54°	64°	40°	46°	55°	64°	45°	46°	56°	65°		60°		66°
標準フック	8tフック																			
フック重量	450kg																			
巻掛本数	1																			

NK-1600-V

# KATO NK-1600-V

■定格総荷重表

●50mブーム+12mヘビ-リフトジブ

(単位:t)

作業半径 (m)	オフセット角																			
	10°				20°				30°				45°				60°			
	A	B	C	D	A	B	C	D	A	B	C	D	A	B	C	D	A	B	C	D
14	13.0	13.0	13.0	13.0																
16	13.0	13.0	13.0	13.0	13.0	13.0	13.0	13.0												
18	13.0	13.0	13.0	13.0	13.0	13.0	13.0	13.0	13.0	13.0	13.0	13.0								
20	13.0	13.0	13.0	13.0	13.0	13.0	13.0	13.0	13.0	13.0	13.0	13.0	12.5	12.5	12.5	12.5	10.7	10.7	10.7	10.7
22	12.3	12.3	12.3	10.8	12.2	12.2	12.2	11.6	12.2	12.2	12.2	12.2	12.5	12.5	12.5	12.5	10.7	10.7	10.7	10.7
24	11.0	11.0	11.0	9.0	11.5	11.5	11.5	9.6	11.5	11.5	11.5	10.2	11.7	11.7	11.7	10.9	10.7	10.7	10.7	10.7
26	9.8	9.8	9.8	7.4	10.3	10.3	10.3	8.0	10.8	10.8	10.8	8.5	11.0	11.0	11.0	9.1	10.7	10.7	10.7	9.4
28	8.8	8.8	8.8	5.9	9.3	9.3	9.3	6.5	9.7	9.7	9.7	7.1	10.3	10.3	10.3	7.6	10.3	10.3	10.3	7.9
30	7.9	7.9	7.3	4.5	8.3	8.3	7.9	5.1	8.7	8.7	8.3	5.7	9.2	9.2	8.8	6.2	9.5	9.5	9.0	6.5
32	7.0	7.0	6.0		7.4	7.4	6.5		7.8	7.8	7.0	4.4	8.2	8.2	7.4	4.9	8.4	8.4	7.6	5.1
34	6.2	6.2	4.7		6.6	6.6	5.3		6.9	6.9	5.7		7.3	7.3	6.1		7.5	7.5	6.3	
36	5.5	5.5	3.6		5.8	5.8	4.1		6.1	6.1	4.5		6.5	6.5	4.9					
38	4.8	4.8			5.1	5.1			5.4	5.4			5.7	5.7						
40	4.2				4.5	4.3			4.7	4.6			4.9	4.9						
45	2.9				3.1				3.2				3.3							
危険角度	30°	44°	52°	60°	30°	45°	53°	60°	30°	45°	53°	60°	45°	53°	62°		60°			62°
標準フック	16tフック																			
フック重量	650kg																			
巻掛本数	2																			

●50mブーム+21mヘビ-リフトジブ

(単位:t)

作業半径 (m)	オフセット角																			
	10°				20°				30°				45°				60°			
	A	B	C	D	A	B	C	D	A	B	C	D	A	B	C	D	A	B	C	D
16	9.5	9.5	9.5	9.5																
18	9.5	9.5	9.5	9.5																
20	9.5	9.5	9.5	9.5	8.8	8.8	8.8	8.8												
22	9.3	9.3	9.3	9.3	8.8	8.8	8.8	8.8												
24	9.1	9.1	9.1	9.1	8.8	8.8	8.8	8.8												
26	8.9	8.9	8.9	8.5	8.8	8.8	8.8	8.8	8.2	8.2	8.2	8.2								
28	8.7	8.7	8.7	7.2	8.6	8.6	8.6	8.0	8.2	8.2	8.2	8.2	7.5	7.5	7.5	7.5				
30	7.9	7.9	7.9	5.9	8.4	8.4	8.4	6.8	8.2	8.2	8.2	7.8	7.5	7.5	7.5	7.5	6.5	6.5	6.5	6.5
32	7.1	7.1	7.1		7.7	7.7	7.7	5.6	7.8	7.8	7.8	6.4	7.5	7.5	7.5	7.3	6.5	6.5	6.5	6.5
34	6.4	6.4	6.1		7.0	7.0	6.9	4.5	7.4	7.4	7.4	5.3	7.5	7.5	7.5	6.1	6.5	6.5	6.5	6.5
36	5.7	5.7	5.0		6.2	6.2	5.8	3.5	6.7	6.7	6.5	4.2	7.1	7.1	7.1	5.1	6.5	6.5	6.5	5.6
38	5.1	5.1	3.9		5.6	5.6	4.7		6.0	6.0	5.4		6.7	6.7	6.2	4.1	6.5	6.5	6.5	4.5
40	4.5	4.5			5.0	5.0	3.8		5.4	5.4	4.4		6.0	6.0	5.1		6.3	6.3	5.5	
45	3.2				3.6	3.6			4.0	4.0			4.4	4.4						
50	2.1				2.4				2.7				3.0							
危険角度	40°	50°	58°	65°	40°	50°	58°	65°	40°	50°	58°	65°	45°	50°	58°	65°		60°		65°
標準フック	16tフック																			
フック重量	650kg																			
巻掛本数	2																			

●50mブーム+30mヘビ-リフトジブ

(単位:t)

作業半径 (m)	オフセット角																			
	10°				20°				30°				45°				60°			
	A	B	C	D	A	B	C	D	A	B	C	D	A	B	C	D	A	B	C	D
20	6.6	6.6	6.6	6.6																
22	6.6	6.6	6.6	6.6																
24	6.6	6.6	6.6	6.6	6.2	6.2	6.2	6.2												
26	6.4	6.4	6.4	6.4	6.1	6.1	6.1	6.1												
28	6.2	6.2	6.2	6.2	6.0	6.0	6.0	6.0	6.0	6.0	6.0	6.0								
30	6.0	6.0	6.0	6.0	5.9	5.9	5.9	5.9	5.9	5.9	5.9	5.9								
32	5.8	5.8	5.8	5.6	5.8	5.8	5.8	5.8	5.8	5.8	5.8	5.8								
34	5.6	5.6	5.6		5.7	5.7	5.7	5.7	5.7	5.7	5.7	5.7	5.2	5.2	5.2	5.2				
36	5.4	5.4	5.4		5.6	5.6	5.6		5.6	5.6	5.6	5.6	5.2	5.2	5.2	5.2				
38	4.9	4.9	4.9		5.4	5.4	5.4		5.5	5.5	5.5	4.8	5.2	5.2	5.2	5.2	4.0	4.0	4.0	4.0
40	4.4	4.4			4.9	4.9	4.9		5.4	5.4	5.4		5.1	5.1	5.1	5.0	4.0	4.0	4.0	4.0
45	3.2	3.2			3.7	3.7			4.2	4.2			4.9	4.9	4.7		4.0	4.0	4.0	
50	2.2				2.6	2.6			3.1	3.1			3.7	3.7			4.0	4.0		
55									2.1				2.6							
危険角度	45°	55°	62°	67°	45°	55°	62°	68°	45°	55°	62°	68°	45°	55°	62°	68°	60°		62°	69°
標準フック	16tフック																			
フック重量	650kg																			
巻掛本数	2																			

次頁へつづく



# KATO NK-1600-V

## ■定格総荷重表

### ●50mブーム+38mヘビーリフトジブ

(単位:t)

作業半径 (m)	オフセット角																				
	10°				20°				30°				45°				60°				
	A	B	C	D	A	B	C	D	A	B	C	D	A	B	C	D	A	B	C	D	
25	3.7	3.7	3.7	3.7																	
30	3.7	3.7	3.7	3.7	3.7	3.7	3.7	3.7													
35	3.7	3.7	3.7	3.7	3.7	3.7	3.7	3.7	3.7	3.7	3.7	3.7									
40	3.7	3.7	3.7		3.7	3.7	3.7	3.7	3.7	3.7	3.7	3.7	3.7	3.7	3.7						
45	3.5	3.5			3.6	3.6	3.6			3.6	3.6	3.6		3.7	3.7	3.7	3.7	3.1	3.1	3.1	3.1
50	2.7	2.7			3.2	3.2				3.4	3.4	3.4		3.5	3.5	3.5		3.1	3.1	3.1	3.1
55	1.9				2.4	2.4				2.8	2.8			3.3	3.3	3.2		3.1	3.1	3.1	
60					1.6					2.0	2.0			2.5	2.5			2.7	2.7		
65														1.6	1.6						
危険角度	45°	55°	62°	68°	45°	55°	62°	68°	46°	55°	62°	69°	46°	55°	62°	69°	60°		62°	70°	
標準フック	8tフック																				
フック重量	450kg																				
巻掛本数	1																				

### ●50mブーム+45mヘビーリフトジブ

(単位:t)

作業半径 (m)	オフセット角																				
	10°				20°				30°				45°				60°				
	A	B	C	D	A	B	C	D	A	B	C	D	A	B	C	D	A	B	C	D	
25	2.7	2.7	2.7	2.7																	
30	2.7	2.7	2.7	2.7																	
35	2.7	2.7	2.7	2.7	2.7	2.7	2.7	2.7													
40	2.7	2.7	2.7		2.7	2.7	2.7	2.7	2.7	2.7	2.7	2.7									
45	2.7	2.7	2.7		2.7	2.7	2.7			2.7	2.7	2.7	2.7								
50	2.4	2.4			2.7	2.7	2.7			2.7	2.7	2.7		2.7	2.7	2.7	2.7				
55					2.3	2.3				2.5	2.5	2.5		2.7	2.7	2.7		2.2	2.2	2.2	2.2
60										2.1	2.1			2.4	2.4	2.4		2.2	2.2	2.2	
65														2.0	2.0			2.2	2.2		
危険角度		56°	62°	68°		57°	63°	69°		58°	63°	70°		58°	63°	70°	60°		64°	72°	
標準フック	8tフック																				
フック重量	450kg																				
巻掛本数	1																				

## ■定格総荷重表の見方

- 定格総荷重表は、水平堅土上において機体を水平に設置した状態での保証できる最大荷重をしめしておりフックその他の吊具の重量を含んだ値です。
- 定格総荷重表はアウトリガ、リヤジャッキ、及びフロントジャッキを使用した状態でアウトリガの張出幅とカウンタウエイトの装備状態との組み合わせにより次の様に区分されます。

〈メインブームの性能区分〉

吊上 方向	アウトリガ 張出幅	カウンタウエイト重量				
		37t	27t	17t	7t	0t
側方	9.2m	A	B	C	D	E
	7.8m	B	C	D	—	—
	6.4m	C	D	—	—	—
	5.0m	—	—	—	—	—
前方	6.4m以上	A	B	C	D	E
後方	6.4m以上	A	B	C	D	E

〈ヘビーリフトジブ及びスーパーラフティングジブ性能区分〉

吊上 方向	アウトリガ 張出幅	カウンタウエイト重量			
		37t	27t	17t	7t
側方	9.2m	A	B	C	D
	7.8m	B	C	D	—
	6.4m	C	D	—	—
	5.0m	D	—	—	—
前方	5.0m以上	A	B	C	D
後方	5.0m以上	A	B	C	D

- 定格総荷重表のブーム角度は、ブームと水平面のなす角度を示し、ジブ角度はブームとジブのなす角度を示します。

- 作業半径はブームのたわみを含んだ値に基づいていますので必ず作業半径を基準として作業を行って下さい。但しスーパーラフティングジブの作業半径は、50mブームにスーパーラフティングジブを装着してジブ作業を行った時の値を示し、その他のブーム長さでのジブ作業はブーム角度だけを基準として行って下さい。
- ブーム長さ、ブーム角度、作業半径、ジブ角度が規定の値を超えた場合は、その規定の値と次の規定の値の定格総荷重のうち小さい方の定格総荷重に従って作業を行って下さい。
- 定格総荷重表の危険角度は、それ以下にブームを下げると無負荷でもクレーンが転倒したり、機械の破損につながる角度を示します。
- スーパーラフティングジブを装着したままでブーム作業を行う場合は、定格総荷重より吊具等の重量の他に13,500kgを差引いて下さい。
- ルースターシーブの定格総荷重はブーム定格総荷重と等しくかつ、限度を8,000kgとします。但し、ブームに吊具等が取付けられている場合には、ブーム定格総荷重より吊具等の重量の他にブームに取付けられているフックの重量も差引いて下さい。
- ヘビーリフトジブの起伏用ロープは必ず掛数にして作業を行って下さい。

ブーム長さ	13.6m	22.7m	31.8m	40.9m	50m
ロープ掛数	6本	6本	6本	4本	4本

- 定格総荷重は風による影響を含んでいません。瞬間風速10m/secを超える場合は作業を中止して下さい。
- 定格総荷重表以外の作業を行った場合及び正しい使い方をしなかった時は転倒又は破損します。この場合本機の保証は致しません。

NK-1600-V

